



DROP-IN **LITHIUM RETROFIT**

**Hassle-free replacement of GC-size
batteries in class III pallet jacks**

AES PROFESSIONAL batteries increase productivity and lower operational costs in Class III pallet jacks, reducing equipment downtime, maintenance, and replacement costs common to lead-acid batteries.

QUICK ROI

One AES PROFESSIONAL battery can replace four 6V lead-acid batteries and last the life of the equipment.

CERTIFIED

UL2271 certification delivers industry leading functional safety and the internal BMS protects from over-discharging.

EASY TO INSTALL

Drop-in replacement of GC2-size batteries and compatible with OEM onboard chargers.

FASTER CHARGE

Can charge up to 5x faster and are 20-30% more efficient than lead-acid batteries. Opportunity charge anytime, regardless of the state of charge.



WHY AES PROFESSIONAL LITHIUM?

SCALABLE

Add batteries to match your energy requirements

HIGH SURGE CURRENT

Lifts with a single battery

LIGHTER WEIGHT

Up to 80% lighter than a lead acid bank

HEATED

Integrated self-heating for cold storage or reefer trucks

LONG-TERM STORAGE

Store powered off for extended periods

IP67

Protect against elements & ideal for wash down or humid environments

BATTERY	SOC GAUGE	ACCESSORIES	
DLP-GC2-24V	BDI Type A PN: 950-0044	DLP T Connector PN:950-0041	DLP TOL-1800 PN: 950-0036
1	1	1	-
2	1	2	1
3	1	3	2
4	1	4	3

NOTE: More than one battery installation is required for heavy load applications or extended runtime.

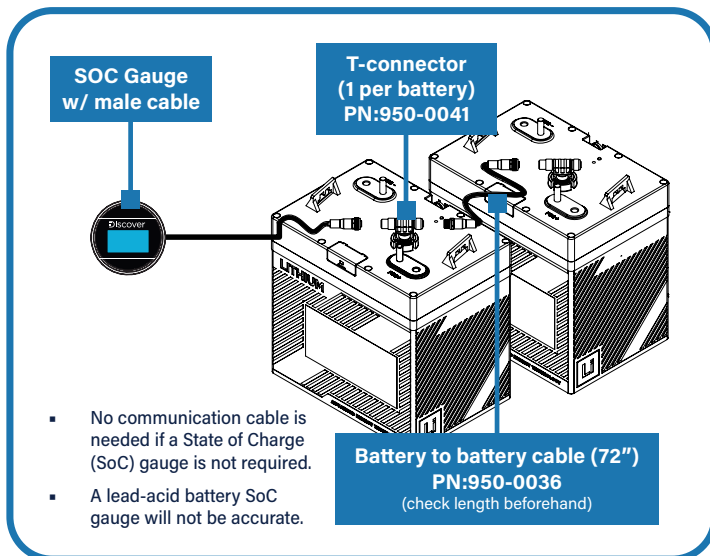
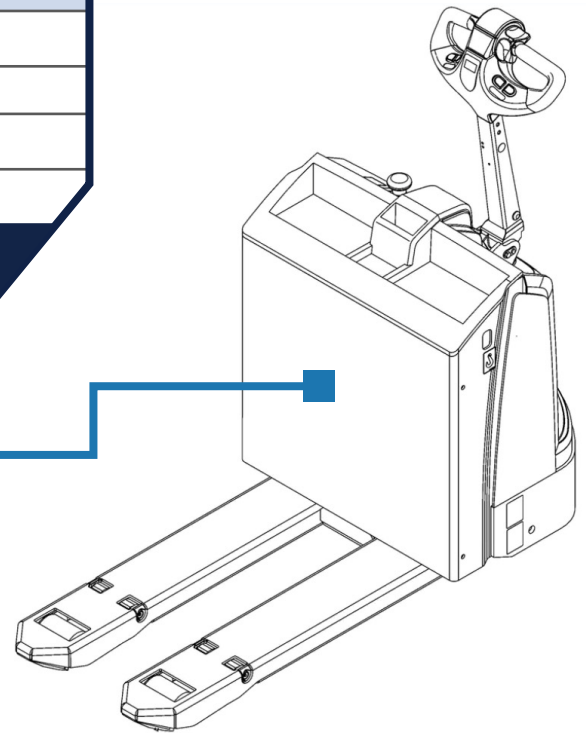

WHY PARTNER WITH DISCOVER AND FUTURE SOLUTIONS?

Future Solutions provides custom energy systems tailored to your industry's specific needs. By partnering with Discover Energy Systems—leaders in energy storage since 1949—we leverage over 75 years of battery expertise to optimize performance, reduce long-term costs, and deliver reliable, innovative power.

